

## chassis 8x8 88.44 / 88.48 / 88.54

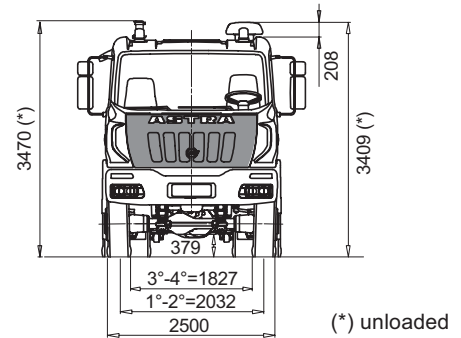

**ON REQUEST**

■ RHD VERSION (opt. code 962)

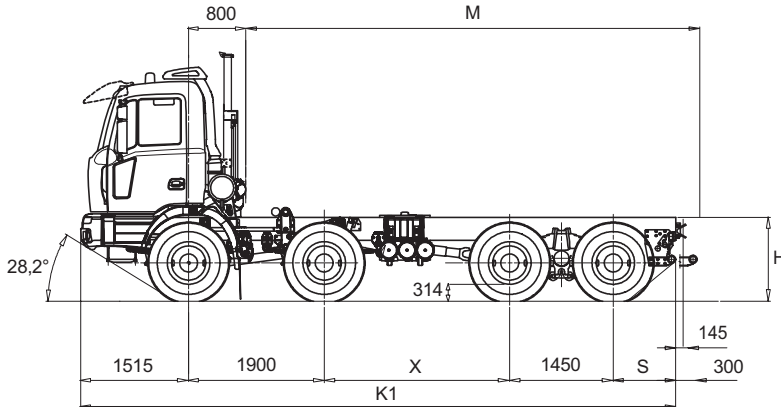

### DIMENSIONS (mm) (Tyres 13R22,5 156/150 G)

X	K1	M max(*)	S	S ON REQUEST	H		TURNING DIAMETER
					unloaded	loaded	
2850	8915	6600	1200	875/1500	1253	1189	19000
3100	9165	6850	1200	875/1500			19700
3350	9415	7100	1200	1500			20500
3600	9965	7650	1500				21300
3960	10325	8010	1500				22800

(\*) M max.: indicative value to be confirmed by bodybuilder.



### WEIGHT (kg)

X	Distribution net weight (*)				Max. technical weight				
	1 <sup>st</sup> axle	2 <sup>nd</sup> axle	3 <sup>rd</sup> +4 <sup>th</sup> axle	net weight	1 <sup>st</sup> +2 <sup>nd</sup> axle		3 <sup>rd</sup> +4 <sup>th</sup> axle	Gross Vehicle weight	Gross Combination weight
2850	3900	3860	4520	12280	16000	17000 18000 (1)	32000	50000 (2)	104000
3100	3910	3880	4530	12320					
3350	3920	3895	4570	12385					
3600	3930	3910	4590	12430					
3960	3940	3920	4620	12480					

(\*)Weight including oil, fuel, spare wheel, driver Kg.75

(1) With tyres 1<sup>st</sup> and 2<sup>nd</sup> axle 385/65R22,5160J or 365/85R20164G. Other tyres available, subject to the Astra technical office approval.

(2) At max speed 50 km/h. Michelin/Pirelli tyres. Higher speeds/loads are allowed with load/speed reductions subject to the Astra Technical office approval.

**Chassis 8x8**



ENGLISH



## ENGINES

CURSOR 13 turbo intercooler **euro 3** diesel injection/cycle with electronic unit injection pumps. 6 in-line cylinders. Single block head, four valves per cylinder, light alloy pistons. Total displacement: 12.882 cm<sup>3</sup>. Bore for stroke: 135 x 150 mm. Water cooling. Viscostatic cooling fan. Dry air filter with safety cartridge. Vertical muffler

	88.44	88.48	88.54*
Model	IVECO F3B	IVECO F3B	IVECO F3B
Max. power (EEC)	324 kW (480 HP)	353 kW (480 HP)	397 kW (540 HP)
Corresponding rpm	1.900		
Max. torque (EEC)	2.100 Nm (214 kgm)	2.200 Nm (224 kgm)	2.350 Nm (239 kgm)
Corresponding rpm	1.000-1.440		1.000-1.690
Turbine	VGT variable geometry		

\*Requires additional engine radiator, for extremely hot climate (>42°C).



## GEARBOX

Manual gear with servoshift, 16 synchronised forward speeds + 2 reverse:

ZF 16 S 2220 TO: HD8 88.44

ZF 16 S 2520 TO: HD8 88.48 and HD8 88.54

On request:

ZF ASTRONIC 16AS2601 OD

ALLISON HD4700: only LHD with X = 3100mm.

		Speed [kph] at maximum power (*)																		
		Gears																		
		1	2	3	4	5	6	7	8	9	10	11	12	13	14	15	16	RM	RM	
ZF 16 S 2220 TO ZF 16 S 2520 TO	Gear ratios	13.80	11.54	9.49	7.93	6.53	5.46	4.57	3.82	3.02	2.53	2.08	1.74	1.43	1.20	1.00	0.84	12.92	10.80	
	Rear axle ratio	1:3.793	9.0	10.8	13.1	15.7	19.1	22.8	27.3	27.3	41.3	49.2	59.9	71.6	87.1	103.8	124.6	148.3	9.6	11.5
		1:4.229	8.1	9.7	11.8	14.1	17.1	20.5	24.5	24.5	37.0	44.2	53.7	64.2	78.1	93.1	111.8	133.0	8.6	10.3
		1:5.009	6.8	8.2	9.9	11.9	14.4	17.3	20.6	20.6	31.2	37.3	45.4	54.2	66.0	78.6	94.4	112.3	7.3	8.7
		1:5.558	6.2	7.4	9.0	10.7	13.0	15.6	18.6	18.6	28.2	33.6	40.9	48.9	59.5	70.9	85.0	101.2	6.6	7.9
		1:6.095	5.6	6.7	8.2	9.8	11.9	14.2	17.0	17.0	25.7	30.6	37.3	44.6	54.2	64.6	77.5	92.3	6.0	7.2
		1:6.588	5.2	6.2	7.6	9.0	11.0	13.1	15.7	15.7	23.8	28.4	34.5	41.2	50.2	59.8	71.7	85.4	5.6	6.6

(\*) Max speed 90 km/h. Other speeds available, subject to the Astra technical office approval.



## P.T.O.

On request:

Gearbox	ZF16S2220TO-ZF16S2520TO	Max. torque	Application
P.T.O.	Ratio	Nm.	
ZF NH/1b	0,91/1,09:1	1000	For tipping unit pumps, pumps for cranes, ecc..
ZF NH/1c	0,91/1,09:1	1000	For tipping unit pumps, unit pumps for concrete, pumps for cranes, ecc..
ZF NH/4c	1,17/1,40:1	430	For tipping unit pumps, ecc..
ZFN221/10bpl+N353/1c	1,75/2,09:1+0,91/1,09:1	560+600	double PTO for concrete pumps

ZF NMV1 221 Power take-off (ratio1,55:1) max available torque 1300 Nm for concrete pumps.

Power take off at flywheel (ratio1,29:1) max available torque 900 Nm for concrete mixers.



## CLUTCH

Single dry plate, diameter 17". Pull type engagement with diaphragm spring. Hydro-pneumatic power steering engagement control, with driven disc wear recovery slave cylinder.



## TRANSFER

Mechanical with two ratios. Based on a series of helical spur gears, mounted on three shafts, engaged with each other. Differential can be locked by pneumatic control.

	HD8 88.44/HD8 88.48	HD8 88.54
Transmission ratio:	1:1 - 1:1,6	1:0,913 - 1:1,407
Front/rear torque distribution ratio:	1:2,2	1:26
	IVECO TC 220	STEYR VG 2700

Technical data and general specifications - validity to be checked according to each individual country.



## AXLES

### FRONT

1<sup>st</sup> and 2<sup>nd</sup> axle, driving and steering, in cast iron with double reduction, central by crown wheel and pinion, lateral by epicyclical group in wheel hubs.

The distributor distributes torque between the two axles. 1<sup>st</sup> and 2<sup>nd</sup> axle wheel stud protection.

### REAR:

Two drive axles in tandem with double reduction, central by bevelled pair and final by epicyclical group in wheel hubs.

The intermediate axle is fitted with distributor that distributes torque between the two axles.

Lockable differential by pneumatic control from driver seat.

The tandem is fitted on the chassis through torque arms with silent block.

### On request:

Rear-axle ratio 1:4.229

Rear-axle ratio 1:5.009

Rear-axle ratio 1:5.558

Rear-axle ratio 1:6.095

Rear-axle ratio 1:6.588

1<sup>st</sup> and 2<sup>nd</sup> axle transversal differential lock



## SUSPENSIONS

### FRONT

1<sup>st</sup> and 2<sup>nd</sup> axle, parabolic springs, n° 3 leaves 26x90 mm, shock absorbers and stabilizer bar on 1<sup>st</sup> axle.

### On request:

Stabilizer bar on 2<sup>nd</sup> axle.

Reinforced parabolic springs, n° 4 leaves 26x90 mm.

Mandatory for heavy duty version.

### REAR

Parabolic springs, swivelling on central pin: n° 4 leaves 40x100 mm, torque bars and stiffening brackets.

Stabilizer bar on 4<sup>th</sup> axle.

### On request:

Stabilizer bar on 3<sup>rd</sup> axle.

Extra-reinforced conventional springs, n° 10 leaves 25x100 mm.



## CHASSIS

Special steel with high elasticity limit, two flat and parallel side members width 820 mm, C section 320x90x10mm, cross members riveted to the frame.

Steel front bumpers with headlamp protection grids, front manoeuvring hook, rear underrun bar, rubber mud-guard on 2<sup>nd</sup> axle, steel fuel tank capacity 300 litres.

### On request:

Front bumper climbing step.

Rapid attachment for compressed air for tyres'inflation.

Rear underrun bar in set back position.

Extra long underrun bar for concrete mixer.

Rear manoeuvring hook.

Rear automatic towing hook.

Rubber mudguards on 3<sup>rd</sup> and 4<sup>th</sup> axle.

Side windlass for spare wheel.



## STEERING

ZF 8099 quadrilateral power steering on front axle wheels with variable ratio 1:22.2/1:26.2 with auxiliary cylinder.

Circuit with main hydraulic pump on engine and emergency pump on gearbox. Steering rods with self-lubricating joints.

Height and inclination mechanically adjustable steering wheel.



## TYRES

**FRONT:** 13R22,5 156/150 G Single - tubeless

**REAR:** 13R22,5 156/150 G Twin - tubeless

Spare wheel on the chassis.

### Other Possible combinations:

TYRES	ASSEMBLY	
	FRONT	REAR
315/80 R 22,5 156/150K 12 00 R 20 156/150G	S	D
385/65 R 22,5 160J*	S	
315/80 R 22,5 156/150K		D
365/85 R 20 164G*	S	S
395/85 R 20 168G*	S	S
525/65 R 20,5 173F		S

S single

D double

Other tyres available, subject to the Astra technical office approval

\* Mandatory with 9t front axle load.



## PNEUMATIC SYSTEM

Two-cylinder 630 cc compressor , APU (Air Processing Unit) that includes: regulation valve set at 10.3 bar, drier, 4-way safety valve, pressure reduction valve for parking circuit and services - 3 air tanks, capacity 30 litres + 2 with 20 litres.

ABS system and EBL (Electronic Brake Limiter)



## BRAKES

Front and rear "duo-duplex" self-adjusting wedge type brakes with automatic play take-up.

Total net braking surface 11.748 cm<sup>2</sup>.

ABS system.

**Service brake:** Pedal controlled air brake, acting on all wheels.

**Solo vehicles,** two independent circuits, one for 1<sup>st</sup> and 2<sup>nd</sup> axle, one for 3<sup>rd</sup> and 4<sup>th</sup> axle;

**Towing vehicles,** three independent circuits, one for 1<sup>st</sup> and 2<sup>nd</sup> axle, one for 3<sup>rd</sup> and 4<sup>th</sup> axle and another for the trailer;

**Emergency brake:** Incorporated in service brake.

**Parking brake:** Mechanical spring-type with pneumatic control acting on 3<sup>rd</sup> and 4<sup>th</sup> axle wheels.

**IVECO BRAKE TURBO engine brake:**

Braking power 255 kW (347 cv)

### On request:

Hydraulic interarder.

1<sup>st</sup> and 2<sup>nd</sup> axle immobiliser system.

OFF/ROAD button for excluding ABS for speed < 15 kph.



## ELECTRICAL SYSTEM

Voltage: 24 V  
 Alternator generator 90 A - 28 V (2520 W).  
 Accumulators: 2 in series, 143 Ah.  
 Starter motor 24 V 5,5 kW.  
 Mechanically controlled electrical circuit breaker.  
 Phonic wheels and sensors on 2<sup>nd</sup> and 4<sup>th</sup> axle.  
 1 electrical joint 7-pole(ISO 7638) for trailer ABS(if applicable).  
 1 electrical joints 15-pole(ISO 12089-4091) for trailer lighting (if applicable).  
 Electrical provision for bodybuilders.  
 Provision for diagnostics.  
 Provision for radio/cb (without speakers)  
 Glow plug for cold start.

### On request:

170 Ah accumulators;  
 143 Ah tropicalised accumulators;  
 170 Ah tropicalised accumulators;  
 220 Ah accumulators;  
 Reverse alarm.



## CAB

White cab with hydraulic tipping. Built in moulding fiberglass with tubular steel armature. Tested on the most demanding off road routes. Cab suspension with guiding arms, spiral springs, double action shock absorbers, anti-roll bar and end-of-stroke pads. Internal panels completely washable and fireproof. 4-speed ventilation and heating system with air recirculation system. Collapsible first step. Electric power windows on driver and passenger doors. Driver seat with pneumatic suspension and belts. Mechanical passenger seat with belts. Tinted athermic windows. Steering wheel adjustable in height and angle.

### On request:

Car radio RDS, CD;  
 Car radio RDS, CD, MP3, Blue Tooth technology;  
 Compressed air quick coupling for cab cleaning;  
 Roof hatch;  
 Air conditioning;  
 Centralized closing of the doors with remote control;  
 Extra colour cab: metallic / non-metallic;  
 Heated and electric powered rear view mirrors;  
 Cab rear window;  
 External sun visor.



## SERVICE DATA(I)

Engine oil sump and filters .....	28
Gearbox oil .....	13
Power steering oil .....	18
Cab tipping oil .....	1
Clutch circuit oil .....	0,5
Transfer oil 88.48 .....	6,5
Transfer oil 88.54 .....	10
1 <sup>st</sup> axle with final red. oil .....	6,5
2 <sup>nd</sup> axle with final red. oil .....	8,8
3 <sup>rd</sup> axle with final red. oil .....	27
4 <sup>th</sup> axle with final red. oil .....	16
Cooling system water .....	33
Diesel .....	300



## INSTRUMENTATION

Dashboard and ergonomic instrument board contain the function buttons and the identification commands.

**Indicator lights:** engine oil low pressure, alternator charging low, main beam lights, side lights, engine warm-up, rear fog light, hazard lights, tractor turn indicators, trailer turn indicators (if applicable), rotating lights, cab lifted, axles differential locked, differential lock, front brakes air pressure low, rear brakes air pressure low, trailer brakes air pressure low (if applicable), parking brake engaged, splitter (reduction on), slow speeds (1-4/9-12), power take-off on (if applicable) air filters clogged, power steering oil level low, rear view mirrors heated (if applicable), ABS, trailer ABS (if applicable), main steering circuit failure, steering auxiliary circuit failure.

### ASTRA Veicoli Industriali

Via Caorsana, 79  
 29122 Piacenza (Italy)  
 Tel. ++39-523/5431  
 Fax ++39-523/59.17.73  
 www.astraspa.com

### DEALER

Characteristics and equipment are subject to changes without prior notice.

Technical data and general specifications - validity to be checked according to each individual country.

